

Embossed Stainless Steel - Floor to Ceiling ELITE MAX SERIES Metal Toilet Partitions

Material Specification

1 . 0 1 Construction

Doors, Panels and Pilasters shall be constructed of two sheets of type 304, Embossed stainless steel with 5WL® pattern, laminated under pressure to a "verticel" honeycomb core for impact resistance, rigidity and sound deadening. Honeycomb to be of virgin, long fiber paper with a maximum 13mm (0.5") cell size. Formed edges to be welded together and interlocked, undertensioned, with a roll-formed oval crown stainless steel locking bar, mitred, welded and ground smooth at the corners.

1 . 0 2 Doors

Shall be between 1854mm (73") - 2336mm (92") high and 25mm (1") thick with cover sheets not less than 0.8mm (.030").

1 . 0 3 Panels

Shall be 1854mm (73") - 2336mm (92") high, with a maximum panel width of 1461mm (57-1/2") and 25mm (1") thick with cover sheets not less than 0.8mm (.030").

1 . 0 4 Pilasters

Shall be 32mm (1.25") thick with cover sheets not less than 1.2mm (.048").

1 . 0 5 Pilaster Fastening Method

AT FLOOR: Pilasters shall be securely and rigidly fastened to the floor and fitted with a jack levelling screw for vertical adjustment. The floor fastening shall be concealed and protected by a 102mm (4") high, die-formed stainless steel pilaster shoe.

AT CEILING: Pilasters shall be rigidly fastened to structural steel or pre-cast concrete supporting member (Note: wood support is not acceptable) by means of two heavy hanging studs permitting vertical adjustment between bottom of supporting member and finished ceiling line. Hadrian supplied ceiling studs MUST be used to create a secure installation. The top connection shall be concealed by a 102mm (4") high, die-formed stainless steel pilaster shoe. NOTE: The specification does not include the supplying, installing, drilling or tapping of any of the structural members required in the ceiling for the support of these units. Only the studs are supplied for installation by others.

1 . 0 6 Hardware & Fittings

Panel-to-pilaster, panel-to-wall, and pilaster-to-wall connections are made with full-height channels, finished to match partitions. A full length aluminum continuous stop and full length aluminum hingeside filler eliminate all sightline gaps between pilasters and doors. Fasteners are #4 brush finished stainless steel 12 x 1-3/4" and 12 x 5/8" TR-27 6-lobe security screws. Each door to be provided with an occupancy Indicator latch #4 brushed stainless steel. Doors shall be equipped with gravity type hinges mounted on upper and lower pilaster hinge brackets. Threaded top hinge pin shall be metal with a self-lubricating nylon sleeve. Door hinges shall be wrap-around style and adjustable to permit the door to come to rest at any position when not latched. Each door to be fitted with a combined #4 brushed finished coat hook and bumper.

1 . 0 7 Finish

All sheet metal to be thoroughly cleaned, phosphated and finished with a high performance powder coating, baked on to provide a uniform smooth protective finish. Color shall be as selected from Hadrian's color card.

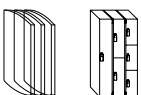

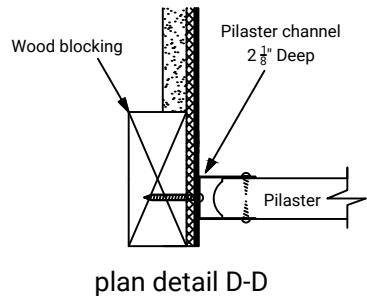
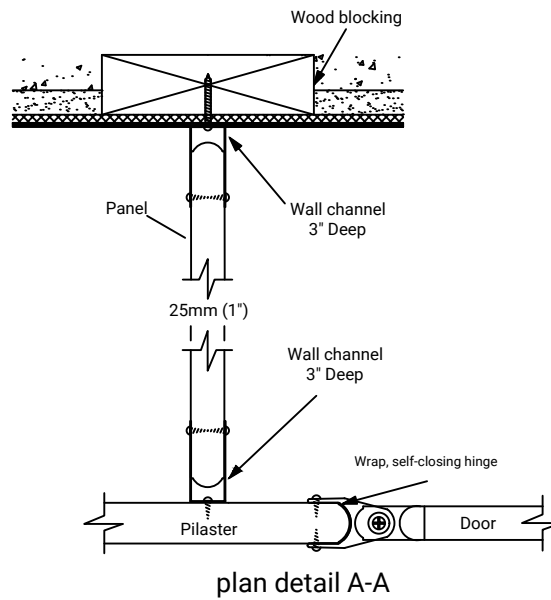
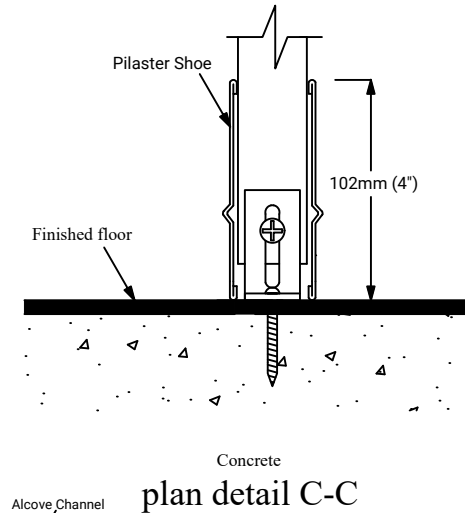
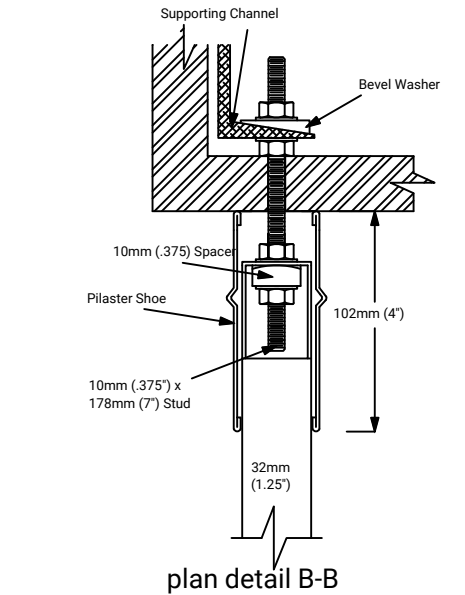
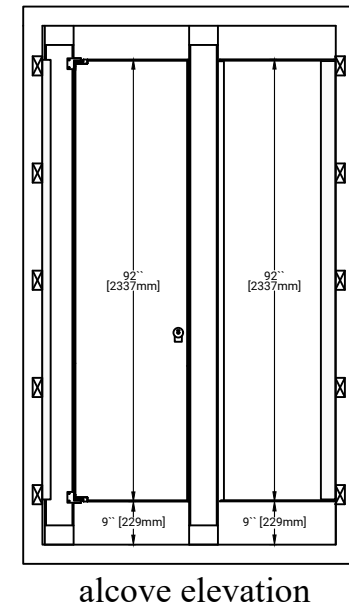
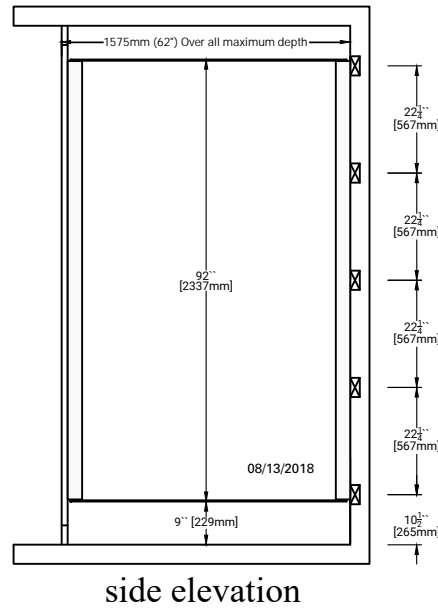
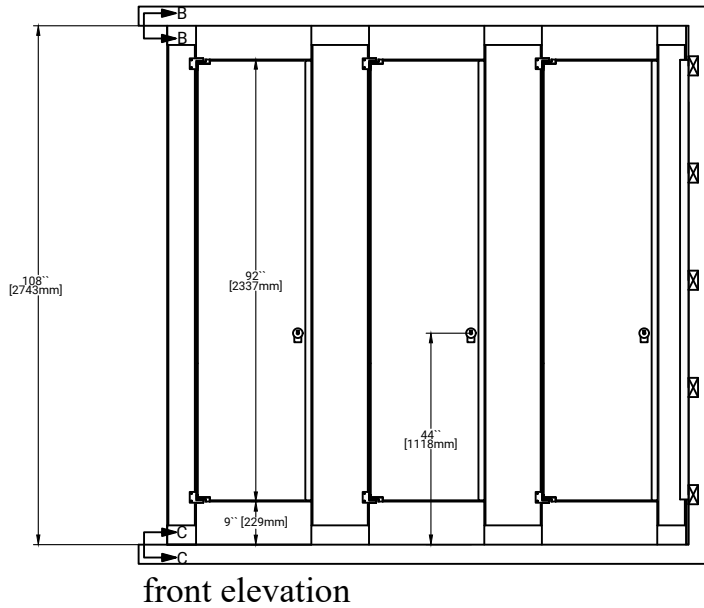

Important Notes:
Refer to final drawings for wood blocking information.
Wood blocking is critical to ensure a rigid installation.

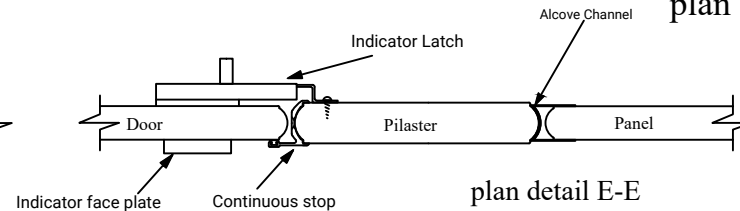

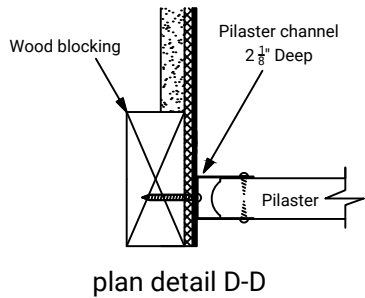
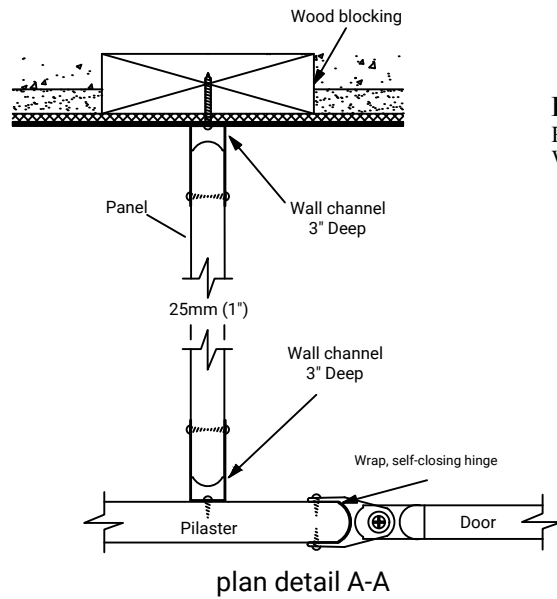
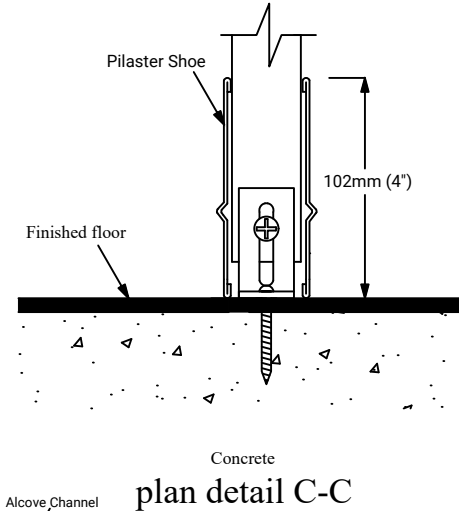
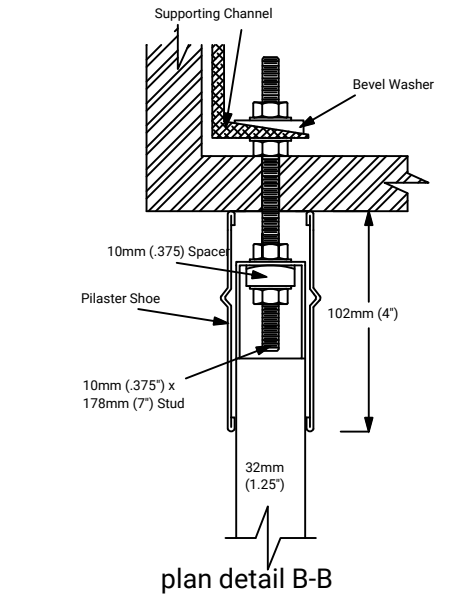
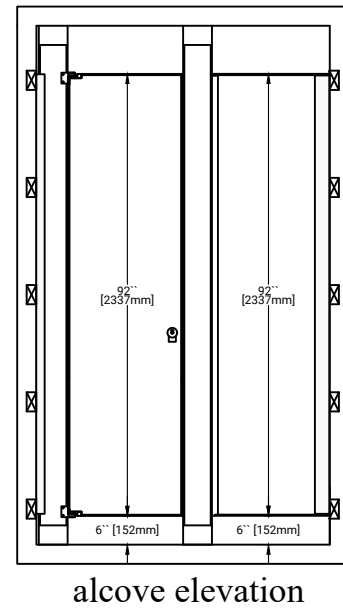
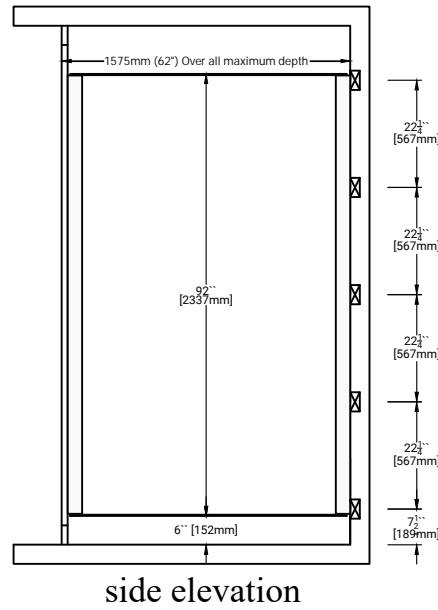
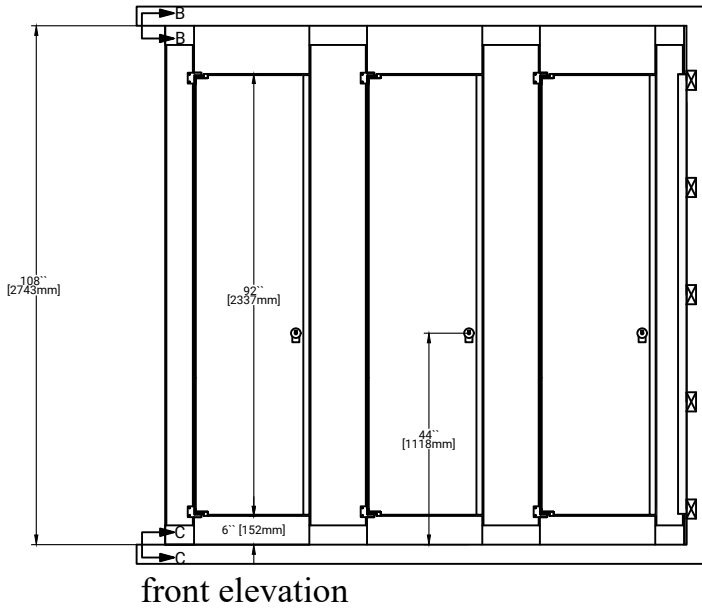

Important Notes:
Refer to final drawings for wood blocking information.
Wood blocking is critical to ensure a rigid installation.

