

**Powder Coated - Floor Mounted  
ELITE SERIES  
Metal Toilet Partitions**

## **Material Specification**

### **1 . 0 1 Construction**

Doors, Panels and Pilasters shall be constructed of two sheets of panel flatness zinc-coated galvanized steel, ASTM A653 GR33, laminated under pressure to a honeycomb core for sound deadening and rigidity. Formed edges to be welded together and inter-locked under tension with a roll-formed oval crown locking bar, mitred, welded and ground smooth at the corners. Honeycomb to have a maximum 25mm (1") cell size.

### **1 . 0 2 Doors**

Shall be 1613mm (63.5") high and 25mm (1") thick with cover sheets not less than 0.8mm (.030").

### **1 . 0 3 Panels**

Shall be 1613mm (63.5") high and 25mm (1") thick with cover sheets not less than 0.8mm (.030").

### **1 . 0 4 Pilasters**

Shall be 32mm (1.25") thick with cover sheets not less than 1.2mm (.048").

### **1 . 0 5 Pilaster Fastening Method**

Pilasters shall be securely and rigidly fastened to the floor using 19mm (.75") diameter expansion shields with spacer and nuts for levelling of pilaster. Floors, preferably concrete, should not be less than 127mm (5") thick for rigidity and anchorage. The floor fastening shall be concealed and protected by a 102mm (4") high, die-formed stainless steel pilaster shoe.

### **1 . 0 6 Hardware & Fittings**

All panel-to-wall, panel-to-pilaster and pilaster-to-wall connections shall be made with full height continuous channels. Door hardware shall be chrome plated zinc die castings. Fasteners are zinc plated 12 x 1-3/4" and 12 x 5/8" TR-27 6-lobe security screws. Doors shall be equipped with gravity type hinges mounted on upper and lower pilaster hinge brackets. Door hinges shall be wrap-around style and adjustable to permit the door to come to rest at any position when not latched. Threaded upper hinge pin shall have a metal core and self lubricating nylon sleeve to ensure smooth, quiet operation. Each door to be fitted with a combined coat hook and bumper and a concealed latch, with face mortised flush with edge strip of door. A full length continuous stop and hinge side filler eliminate all sightline gaps between pilasters and doors.

### **1 . 0 7 Finish**

All sheet metal to be thoroughly cleaned, phosphated and finished with a high performance powder coating, baked on to provide a uniform smooth protective finish. Color shall be as selected from Hadrian's color card.

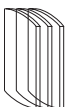

# hadrian<sup>®</sup> ELITE SERIES - Metal Toilet Partitions - Floor Mounted - 9" AFF

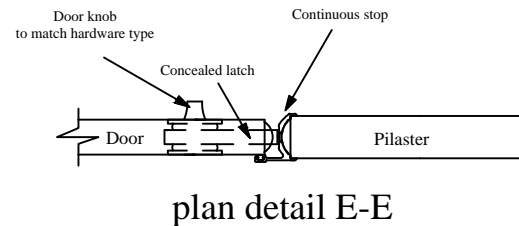
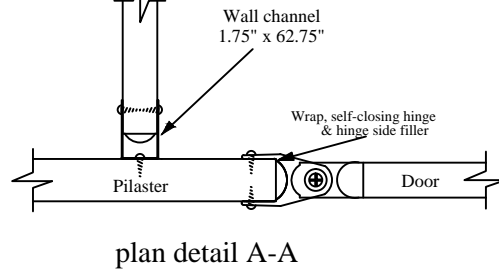
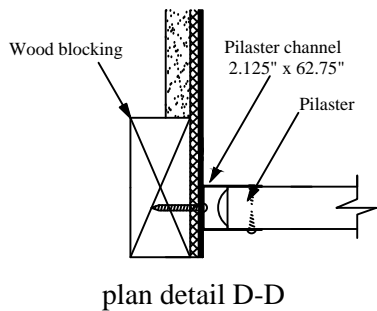
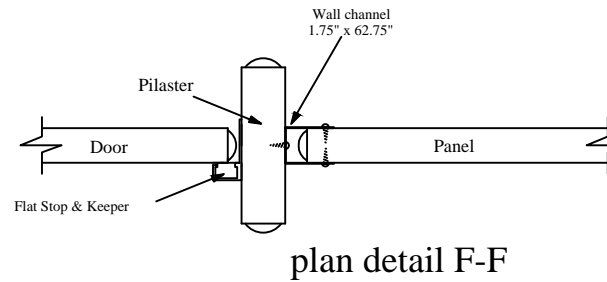
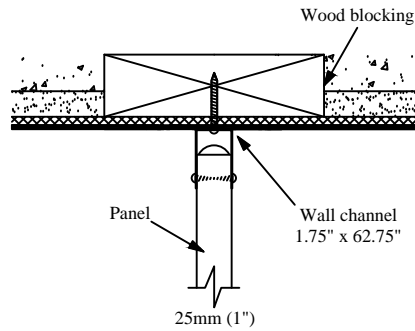
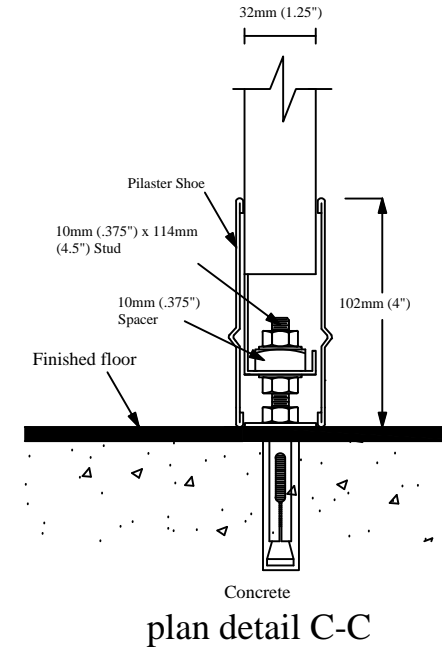
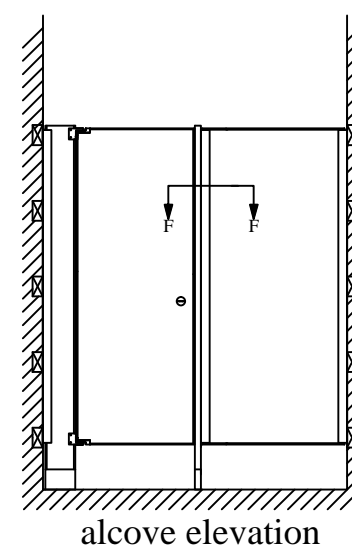
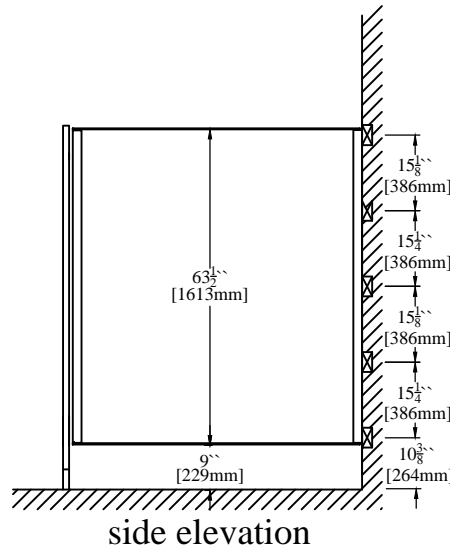
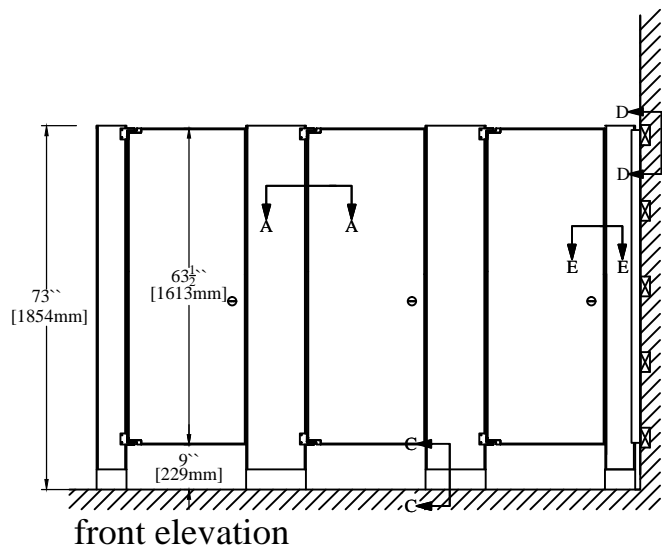

**Important Notes:**  
Refer to final drawings for wood blocking information. Wood blocking is critical to ensure a rigid installation.



**Hadrian Manufacturing Inc.**  
**Hadrian Inc.,**  
[www.hadrian-inc.com](http://www.hadrian-inc.com)

965 Syscon Road, Burlington, ON, Canada, L7L 5S3  
7420 Clover Avenue, Mentor, OH, U.S.A., 44060

• Tel: (905) 333-0300 • Fax (905) 333-1841  
• Tel: (440) 942-9118 • Fax (440) 942-9618