

Stainless Steel - Floor to Ceiling ELITE PLUS SERIES Metal Toilet Partitions

Material Specification

1 . 0 1 Construction

Doors, Panels and Pilasters shall be constructed of two sheets of panel flatness type 304, #4 brushed finish stainless steel, laminated under pressure to a "verticel" honeycomb core for impact resistance, rigidity and sound deadening. Honeycomb to be of virgin, long fiber paper with a maximum 13mm (0.5") cell size. Formed edges to be welded together and interlocked, under tension, with a roll-formed oval crown stainless steel locking bar, mitred, welded and ground smooth at the corners.

1 . 0 2 Doors

Shall be 1829mm (72") high and 25mm (1") thick with cover sheets not less than 0.8mm (.030").

1 . 0 3 Panels

Shall be 1829mm (72") high and 25mm (1") thick with cover sheets not less than 0.8mm (.030").

1 . 0 4 Pilasters

Shall be 32mm (1.25") thick with cover sheets not less than 1.2mm (.048").

1 . 0 5 Pilaster Fastening Method

AT FLOOR: Pilasters shall be securely and rigidly fastened to the floor and fitted with a jack levelling screw for vertical adjustment. The floor fastening shall be concealed and protected by a 102mm (4") high, die-formed stainless steel pilaster shoe.

AT CEILING: Pilasters shall be rigidly fastened to structural steel or pre-cast concrete supporting member (Note: wood support is not acceptable) by means of two heavy hanging studs permitting vertical adjustment between bottom of supporting member and finished ceiling line. Hadrian supplied ceiling studs MUST be used to create a secure installation. The top connection shall be concealed by a 102mm (4") high, die-formed stainless steel pilaster shoe. NOTE: The specification does not include the supplying, installing, drilling or tapping of any of the structural members required in the ceiling for the support of these units. Only the studs are supplied for installation by others.

1 . 0 6 Hardware & Fittings

All panel-to-wall, panel-to-pilaster and pilaster-to-wall connections shall be made with full height channels. Door hardware shall be chrome plated zinc die castings, standard. Fasteners are 12 x 1-3/4" and 12 x 5/8". Doors shall be equipped with gravity type hinges mounted on upper and lower pilaster hinge brackets. Door hinges shall be wrap-around style and adjustable to permit the door to come to rest at any position when not latched. Threaded upper hinge pin shall have a metal core and self lubricating nylon sleeve to ensure smooth, quiet operation. Each door to be fitted with a combined coat hook and bumper and a concealed latch, with face mortised flush with edge strip of door. A full length continuous stop and hinge side filler eliminate all sightline gaps between pilasters and doors.

1 . 0 7 Finish

Type 304, #4 brushed finish.

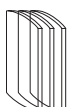

hadrian[®] ELITE PLUS SERIES - Metal Toilet Partitions - Floor to Ceiling - 6" AFF

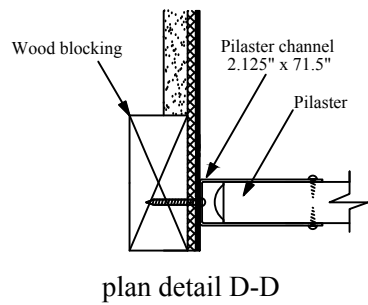
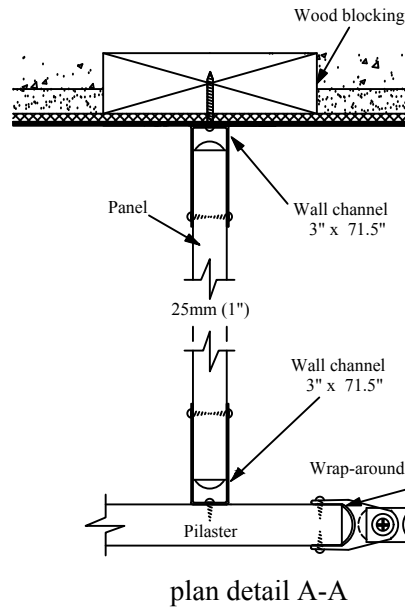
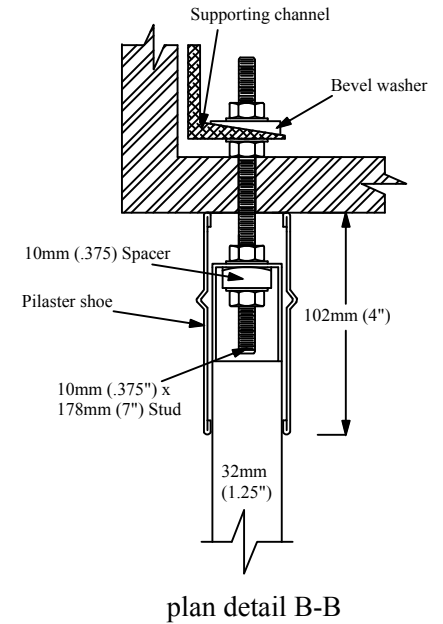
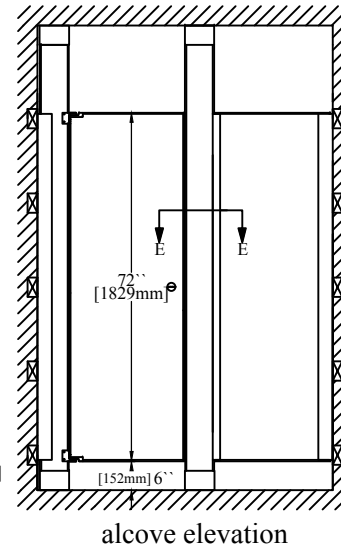
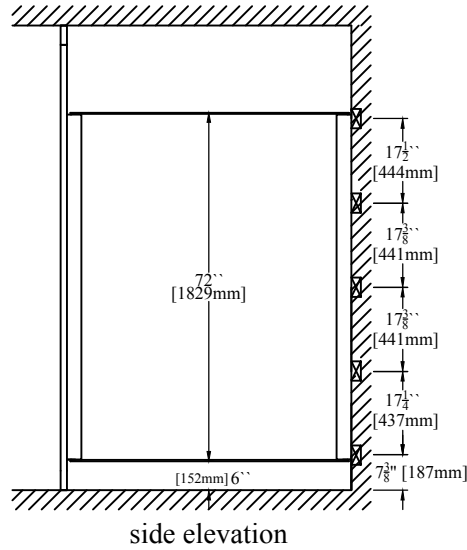
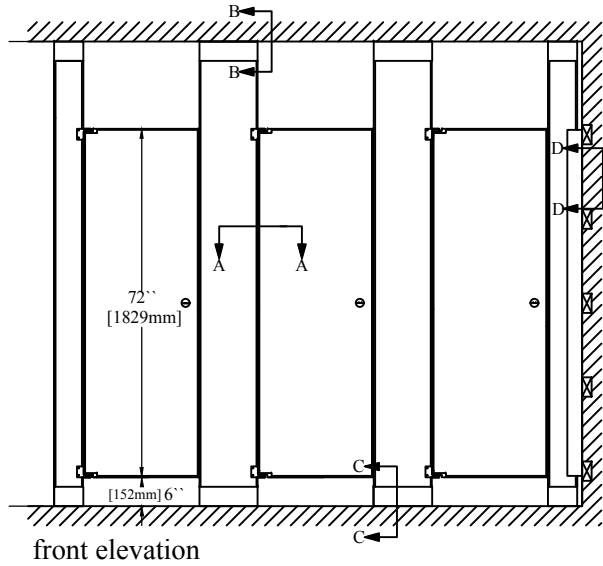

Important Notes:

Structural steel or pre-cast concrete as support in ceiling. Structural support and drilling for studs by others. studs available from Hadrian but installed by others.

Refer to final drawings for wood blocking information. Wood blocking is critical to ensure a rigid installation.

Hadrian supplied ceiling studs MUST be used to create a secure installation.

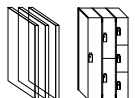
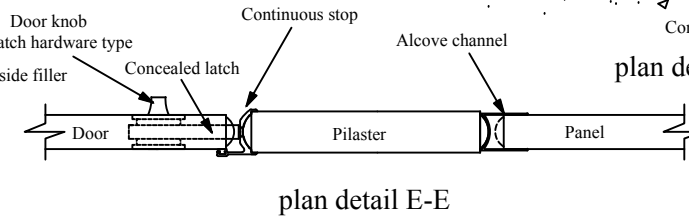
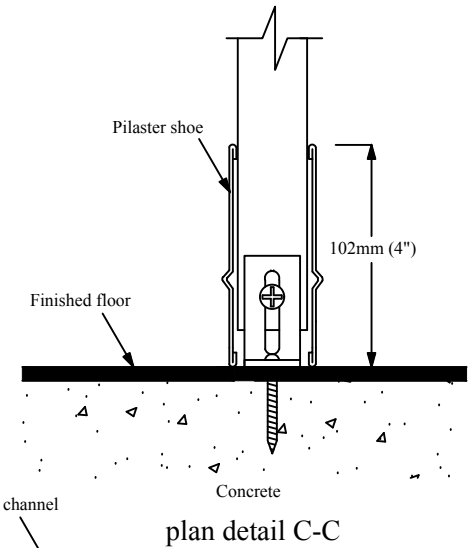

Hadrian Manufacturing Inc.
Hadrian Inc.,
www.hadrian-inc.com

965 Syscon Road, Burlington, ON, Canada, L7L 5S3
 7420 Clover Avenue, Mentor, OH, U.S.A., 44060

• Tel: (905) 333-0300 • Fax (905) 333-1841
 • Tel: (440) 942-9118 • Fax (440) 942-9618

hadrian[®] ELITE PLUS SERIES - Metal Toilet Partitions - Floor to Ceiling - 9" AFF

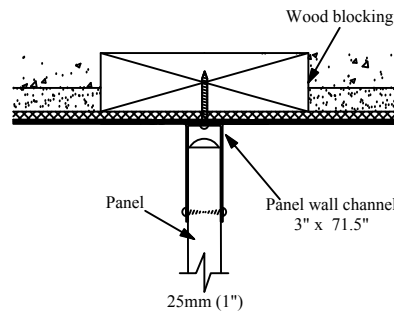
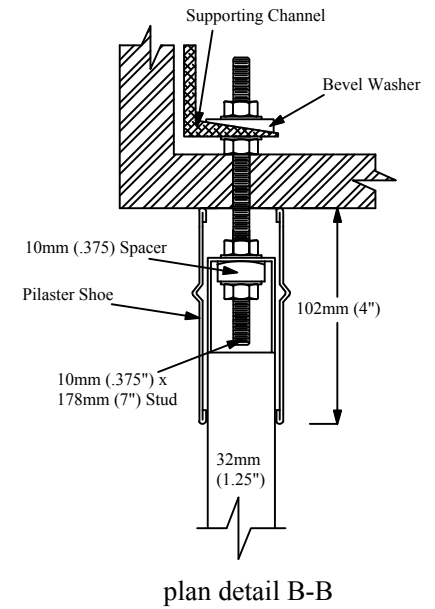
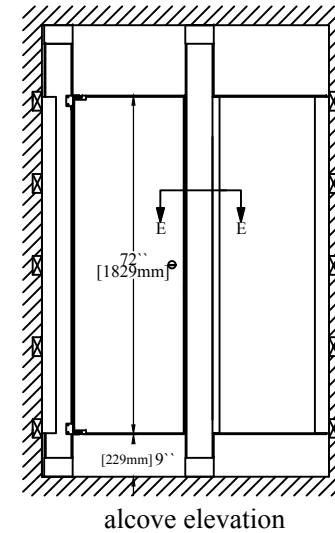
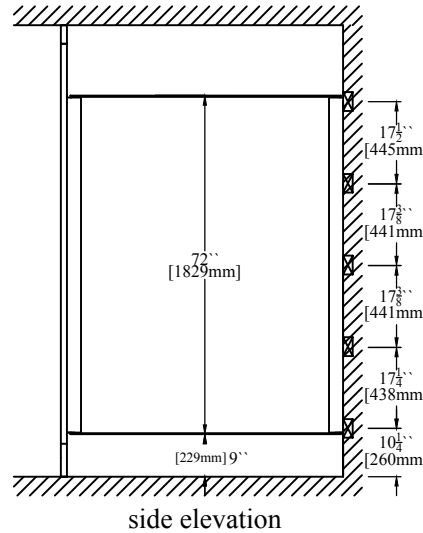
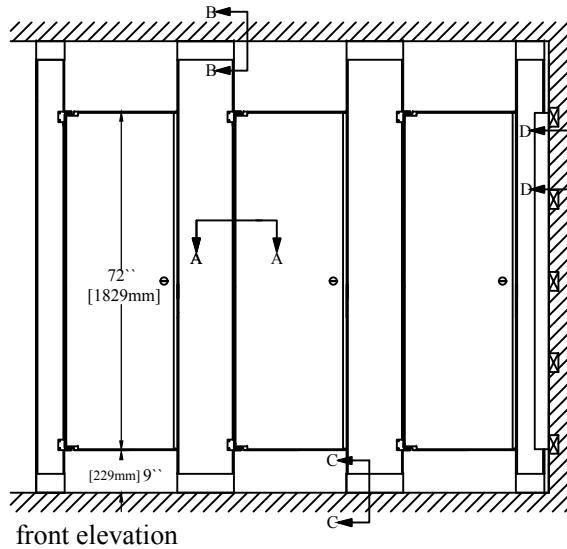

Important Notes:
Structural steel or pre-cast concrete as support in ceiling.
Structural support and drilling for studs by others. Studs available from Hadrian but installed by others.

Refer to final drawings for wood blocking information. Wood blocking is critical to ensure a rigid installation.

Hadrian supplied ceiling studs **MUST** be used to create a secure installation.

Maximum recommended floor to ceiling distance: 3099mm (122 inch)

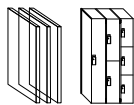
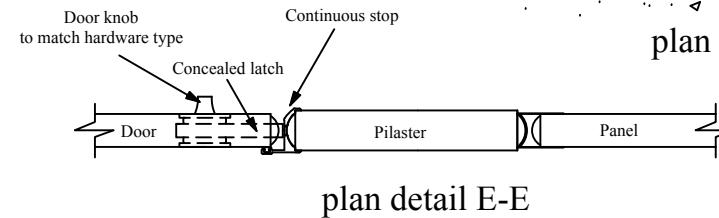
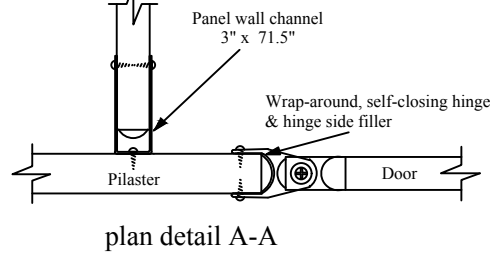
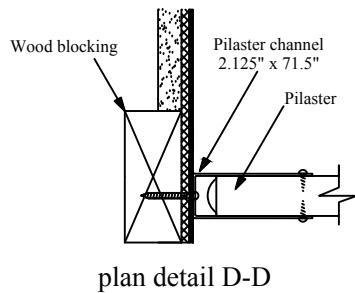
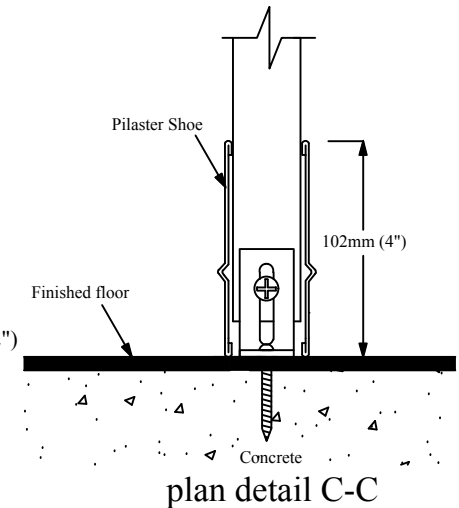

Hadrian Manufacturing Inc.
Hadrian Inc.,
www.hadrian-inc.com

965 Syscon Road, Burlington, ON, Canada, L7L 5S3
7420 Clover Avenue, Mentor, OH, U.S.A., 44060

Tel: (905) 333-0300 · Fax (905) 333-1841
Tel: (440) 942-9118 · Fax (440) 942-9618