

LOCKERS

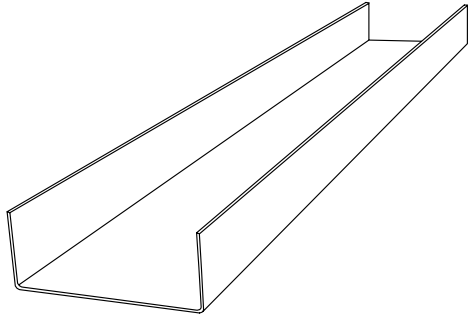

Trim and Fillers *locker accessories*

Hadrian's Trim and Filler pieces promote a clean and consistent appearance throughout the locker area by closing off unsightly gaps. All pieces are powder coated in any of Hadrian's designer colors to match the lockers. The end result is an attractive, durable, and uniform installation.

hadrian
toilet partitions and lockers

www.hadrian-inc.com

Specifications: Section 10500

Part 1 - General

1.01 **Qualifications**

Qualifications of alternative products will be evaluated only if they are submitted with supporting documents to show that they are equal to or better than these specification standards.

1.02 **Chemical Safety**

All materials are completely asbestos free. The paint used shall be a powder coating completely free of all lead and chromate.

1.03 **Warranty**

Hadrian's Trim and Filler pieces are warranted for a period of two years against defective parts and workmanship, excluding vandalism and improper installation.

Part 2 - Products

2.01 **Materials**

"U" Fillers shall be made of 18 gauge and all other Trim and Fillers shall be made of 24 gauge mild cold rolled sheet steel free from surface imperfections and contaminants that would be detrimental to the acceptance of a high grade hybrid epoxy polyester powder finish. At a slight extra cost, locker parts may be made from galvalume steel.

Trim Angle

If a gap exists at the end of lockers in a corner, attach trim angles.

Starter Trim attaches to the wall and the Expansion Angle attaches to the locker.

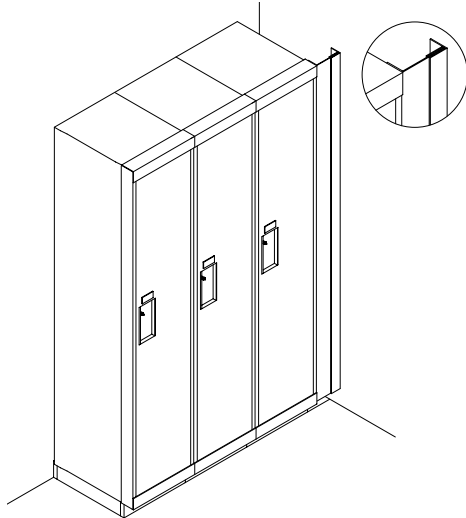

Starter Trim

Made from 24 gauge material.

Available sizes:

- 1" (25mm) x 72" (1829mm)
- 2" (51mm) x 72" (1829mm)
- 1" (25mm) x 60" (1524mm)
- 2" (51mm) x 60" (1524mm)

Expansion Angle

Made from 24 gauge material.

Available sizes:

- | | |
|----------------------------|----------------------------|
| 1" (25mm) x 72" (1829mm) | 1" (25mm) x 60" (1524mm) |
| 2" (51mm) x 72" (1829mm) | 2" (51mm) x 60" (1524mm) |
| 3" (76mm) x 72" (1829mm) | 3" (76mm) x 60" (1524mm) |
| 4" (102mm) x 72" (1829mm) | 4" (102mm) x 60" (1524mm) |
| 5" (127mm) x 72" (1829mm) | 5" (127mm) x 60" (1524mm) |
| 6" (152mm) x 72" (1829mm) | 6" (152mm) x 60" (1524mm) |
| 12" (305mm) x 72" (1829mm) | 12" (305mm) x 60" (1524mm) |

Note: Starter Trim and Expansion Angles also available in 18 gauge material. Contact Hadrian for details.

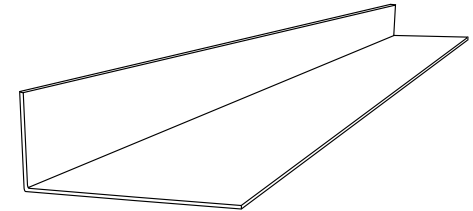
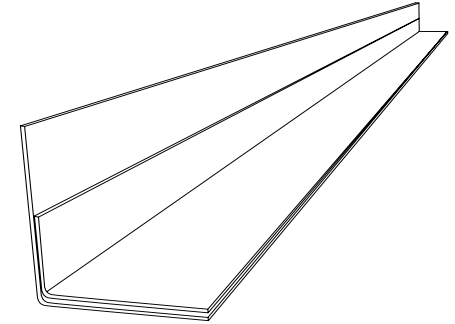

Filler Panel

If a gap exists between two banks of lockers, or to cover pipes or other unsightly elements, install a "U" shaped filler panel.

Install with fasteners from inside lockers to maintain a clean exterior with no exposed fasteners.

"U" Shaped Filler Panel

Made from 18 gauge material.

Available sizes:

- | | |
|----------------------------|----------------------------|
| 8" (203mm) x 72" (1829mm) | 8" (203mm) x 60" (1524mm) |
| 10" (254mm) x 72" (1829mm) | 10" (254mm) x 60" (1524mm) |
| 12" (305mm) x 72" (1829mm) | 12" (305mm) x 60" (1524mm) |
| 15" (381mm) x 72" (1829mm) | 15" (381mm) x 60" (1524mm) |
| 18" (457mm) x 72" (1829mm) | 18" (457mm) x 60" (1524mm) |

